

THRUSTERS



PETTER'S MARINE HYDRAULICS has since 1988 manufactured and delivered over 1000 thrusters to the off-shore, fishing, shipping and aquaculture industries. Thrusters are essential in providing good vessel control in docking, at slow speed, in narrow water maneuvering, emergency steering and position keeping. Our thrusters provide high efficiency and can be adapted to any type of hull.

PETTER'S MARINE HYDRAULICS' thrusters are made for operations in demanding environments and tough conditions, providing **EXCELLENT** performance and high **RELIABILITY** in a **COST EFFICIENT** way.



Fixed pitch propeller, optimized of the thruster dimension and motor power.

PETTER'S MARINE HYDRAULICS has through the last decades developed a series of thrusters to be included in our standard "off the shelf" products, available on short-time-delivery basis. However, we also design and manufacture thrusters according to customer specifications, which then are tailored to provide optimum efficiency for a specific vessel. Our product range consists of hydraulic thrusters from a small and compact 15 HP unit up to a robust and powerful 500HP unit, together with electric thrusters from 110kW to 370kW. All our standard thrusters are available in steel, aluminum and fiberglass. We also make special adjustments to our design upon customer's request, where some parameters can be manipulated to fit the current hull design. In the year 2000, **PETTER'S MARINE HYDRAULICS** delivered a record breaking fiberglass thruster of 300HP, and in 2013 we aim to introduce a 500HP fiberglass thruster to the market.

We offer two thruster designs: ST and STR.

STR-DESIGN

The STR-thrusters has a conventional straight tunnel design, with an angular transmission and a motor oriented orthogonally to the thruster tunnel. The angular transmission makes the thruster ideal for mounting underneath the main propeller shaft. The STR-design is available both for hydraulic and electric motors.

ST-DESIGN

The ST-thruster is easily recognized by its compact design, angled tunnel and straight drive shaft. The great advantage of this thruster design is the low complexity, with few parts and low maintenance requirements. The lack of a big and bulky angular transmission, allows for more water to flow unobstructed through the tunnel, increasing its efficiency. The fact that the thruster is angled in a downward angle proves to be its biggest advantage. Installing ST thrusters in catamaran or trimaran hulls assures that the water jet is pushed underneath the neighboring hull and not straight into it, dramatically reducing its efficiency. The thruster design is very compact and can be fitted in the narrowest of hulls. The ST design is available with hydraulic motors and in steel, aluminum and fiberglass tunnels.

FIXED PITCH

Fixed pitch propellers are standard on all our thrusters, where each propeller is optimized to the thruster design. Fixed pitch propellers requires less space than adjustable ones, allowing more water to flow through the thruster tunnel, providing more thrust. The great advantage with fixed pitch propellers is the low level of complexity; making it long lasting, low maintenance and reliable, but most important of all: low cost.

HYDRAULIC OR ELECTRIC?

Hydraulic thrusters have the advantage of being more compact than electric ones, where the hydraulic motor is rather small in

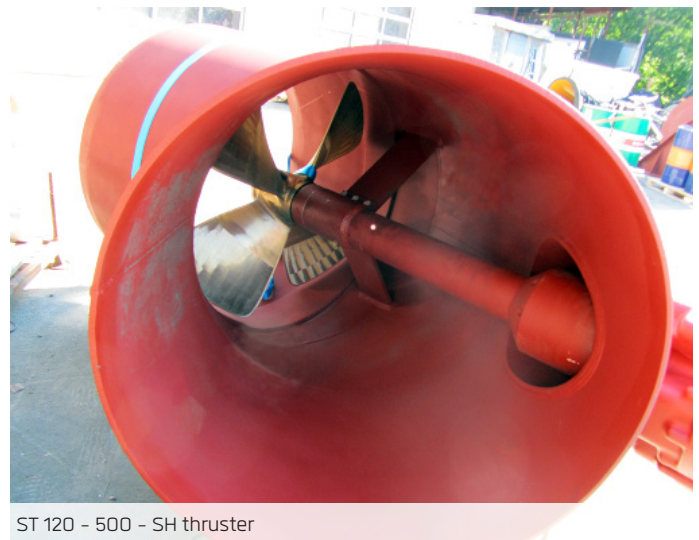

ST 120 - 500 - SH thruster

comparison. This gives great advantages when fitting the thruster in a narrow spaced hull with little or no room to spare, a challenge often met when retrofitting a thruster in an old hull. Hydraulic pumps and oil tanks can then be installed remote to the thruster in a more suitable location onboard. On the other hand, electric motors do not require big and noisy pumps and pipelines, together with oil spill and space consuming tanks. Performing electric installations are in general easier and less time consuming than hydraulic installations, and requires less maintenance when in use.

ST design:

- Angled tunnel
- Direct drive shaft
- Low complexity
- Low maintenance
- Hydraulic drive
- Adaptable to any hull
- Steel, aluminum and fiberglass

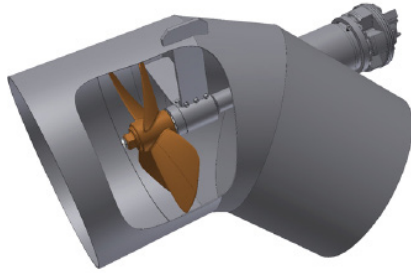

STR design:

- Straight tunnel
- Angled gear
- Low complexity
- Low maintenance
- Hydraulic or electric drive
- Especially suited for mounting under the main propeller shaft

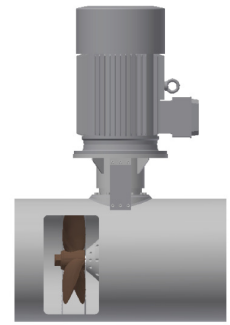

PETTER'S MARINE HYDRAULICS aims to satisfy our customers by providing reliable products with excellent performance and customer support.

For the customer that demands a little bit more, **PETTER'S MARINE HYDRAULICS** offers a support contract that ensures 24/7 technical phone support and on-site support within 24 hours if a breakdown or malfunction should occur. We also offer service contracts for periodic maintenance of all equipment, including software updates

STANDARDS & CERTIFICATIONS

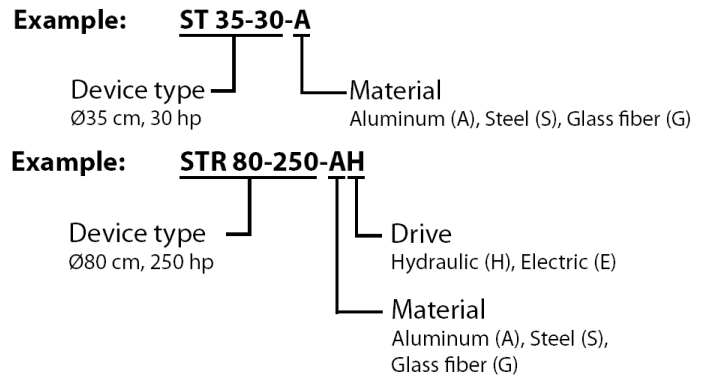
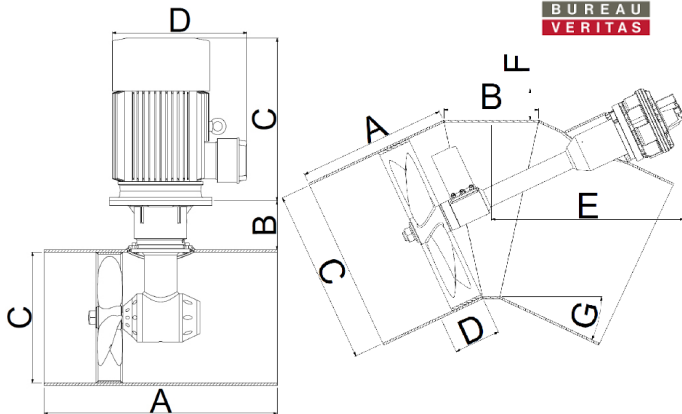

ST DESIGN - TECHNICAL DATA

Device	Power	Max RPM	Flow	Pres.	Thrust	Tun. thckn.	A	B	C	D	E	F	G	Lubri.
ST25 - 15 - x	15 HP	2200	35	200	> 0.12 t	A10 / S6 mm	235*	150	Ø250	110	335	125	30°	WR2
ST35 - 30 - x	30 HP	1700	51	280	> 0.25 t	A8 / S6 mm	365*	225	Ø350	125	445	202	30°	WR2
ST45 - 50 - x	50 HP	1330	82	280	> 0.40 t	A8 / S6 mm	400*	268	Ø460	135	561	233	30°	WR2
ST60 - 80 - x	80 HP	1200	135	280	> 0.65 t	A10 / S8 mm	530*	346	Ø620	200	795	232	25°	WR2
ST65 - 160 - x	160 HP	820	270	270	> 1.30 t	A10 / S10 mm	700*	390	Ø690	220	853	194	25°	VG 32
ST100 - 300 - x	300 HP	550	250	550	> 2.40 t	A15 / S12 mm	900*	575	Ø1050	300	1166	190	25°	VG 32
ST100 - 500 - x	500 HP	550	300	755	> 4.00 t	A15 / S12 mm	900*	583	Ø1050	330	1366	355	25°	VG 32
ST120 - 500 - x	500 HP	450	900	500	> 4.00 t	A15 / S12 mm	1100*	685	Ø1250	350	1500	340	25°	VG 32

*Some of the listed dimensions are flexible. By changing the parameter A on the left side (right side accordingly) the thruster is adaptable to most hull designs. Standard material thickness, can be changed if the customer requires it. Oil flow and pressure may vary with the mounted motors and the hydraulic system.

STR DESIGN - TECHNICAL DATA

Device	Power	Max RPM	Thrust	Oil pres.	Oil flow	Tun. thckn.	A	B	C	D	Lubrication
STR80 - 150 - xH	150 HP	700	> 0.12 t	270 Bar	260 l/min	15 mm	1500*	302	844	290	Orion 870 80W90 or Omega 690
STR80 - 150 - xE	120 kW	700	> 0.12 t	-----	-----	15 mm	1500*	316	844	864	
STR80 - 250 - xH	250 HP	830	> 0.20 t	280 Bar	410 l/min	15 mm	1500*	302	844	290	
STR80 - 250 - xE	200 kW	830	> 0.20 t	-----	-----	15 mm	1500*	316	844	864	

*Some of the listed dimensions are flexible. By changing the parameter A on the left side (right side accordingly) the thruster is adaptable to most hull designs. Standard material thickness, can be changed if the customer requires it. Oil flow and pressure may vary with the mounted motors and the hydraulic system.



STANDARD MANEUVERING SOLUTIONS

Manufacturer of TYPE APPROVED PRODUCTS:

- STEERING GEARS
- ANCHOR WINCHES



PETTER'S MARINE HYDRAULICS

web: www.pmh.no

switchboard +47 73 96 26

E-mail: post@pmh.no