

Design according to Norwegian Maritime
Authorities rule No.1853 and ISO7365

ANCHOR HANDLING AND TOWING WINCH



DW60-D20-Lxx

SWL 20t

TYPETABLE

Hydraulic connections	
P, T DRAIN, LS	38x4, 42x3, 28x2, 12x1.5
Hydraulic motors	3 pcs
Gear with brakes	3 pcs
Oil pressure, flow	220Bar, 200l/min nom.
Motor displacement	Variable: 25 - 60ccm
Max towing load/anchor weight	Layer 1: 32,6t
Towing line: MBL acc. to ISO 7365	79,1t
Pull force for anchor handling, Ø64mm	Layer 1: 20t Last Layer: 16t

PMH DW60-D20-Lxx is a multi purpose winch for anchor handling and towing, built according to Norwegian Maritime Authorities rule "No. 1853 on construction and supervision of smaller cargo ships" and dimensioned in accordance with ISO7365. Lxx refers to the drum lengths the winch can be delivered with. The winch has a torque that corresponds to 60 tons, but the SWL is 20 tons on all layers on the winch.

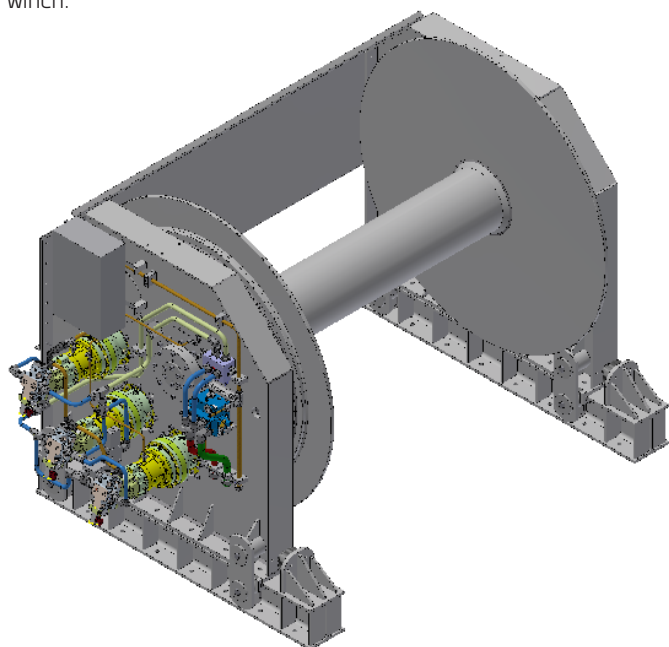

DW60-D20-Lxx with tension control

PMH DW60-D20-Lxx is equipped with an emergency release, load sensing, programmable load-control system and a logging functionality.

SPLITTED DRUM (S)

The winch can also be delivered with a splitted-drum to achieve the possibility of pulling 20 tons with 1860m (Ø64mm) rope on the storage side of the drum.

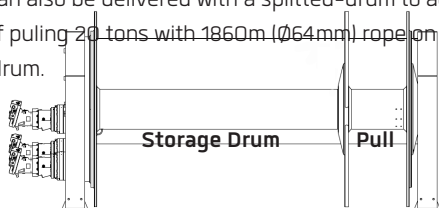

DW60-D20-L32-S

EMERGENCY RELEASE

The Emergency release enables the winch to release the rope with a residual force of less than 2 tons on the middle layer.

LOAD SENSING AND LIMITING SYSTEM

The winch is equipped with an electronic control system for sensing and limiting the load, in accordance with new regularions given by the Norwegian Maritime Authorities rule "No. 1853 on construction and supervision of smaller cargo ship".

The control system has two different modes: "**Tension Mode**" and "**Minimum Load Mode (no mode)**". Modes can only be selected from the touch screen in the system's control panel.

In **Tension Mode (main mode)**, the operator can enter the maximum limit for the current operation based on the rope's breaking strenght or the anchor's fastening strength. The system will automatically limit the maximum capabilities at the given strength, and the secure load will not exceed this limit.

In **Minimum Load Mode (no mode)**, the heave capability will be reduced to a minimum. This mode is only active when **Tension Mode** is not selected or in an blackout of the control system.

LOGGING OF ALL OPERATIONS

During all operations with loads over 200kg, the system will automatically log all data. The log includes date and time, load data, active operator mode, hydraulic pressure and, if available, the geographic coordinates of the vessel. All data are logged to a USB drive. The USB drive has to be present before any mode can be selected. If removed during operation, the system will automatically activate the **Minimum Load Mode (no mode)**.

Norwegian Fishing Authoreties NYTEK rules, § 19 requires logging during anchor mooring processes within the aquculture industry.

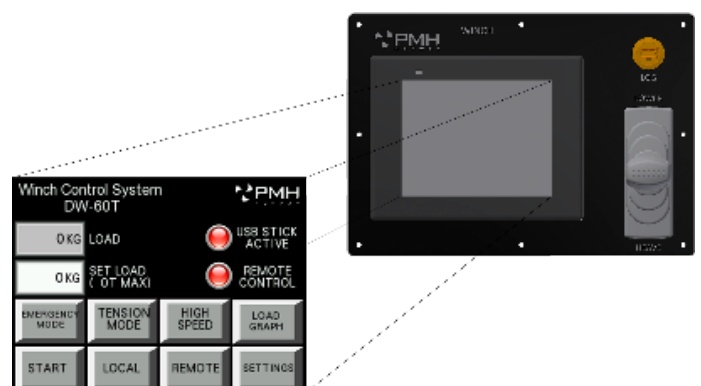

Log file

The log file on USB drive, can be imported into spreadsheets, like MS Excel, for further analysis. This log data contains all information as described above.

WIRELESS REMOTE CONTROL (OPTION)

The winch can also be delivered with a wireless remote control. This remote control system can also be programmed to control other deck equipment.

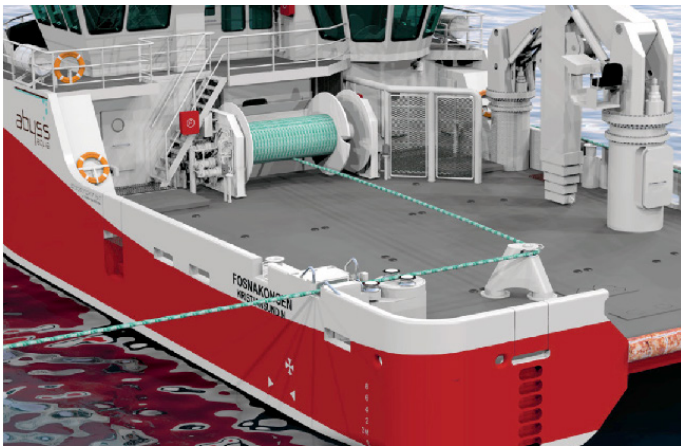

DW60-D20-L32-S delivered to the vessel. Fosnakongen, operating with the deck equipment "Safe Work on Deck".



DW60-D20-Lxx is the perfect winch for tensioning any mooring arrangement. Together with the "Rope Lock" it will become a unique tool! See our brochure for "Safe Work on Deck".

Winch design:

- Variable speed
- Emergency Release
- High drum capacity
- Steel
- Hydraulic drive

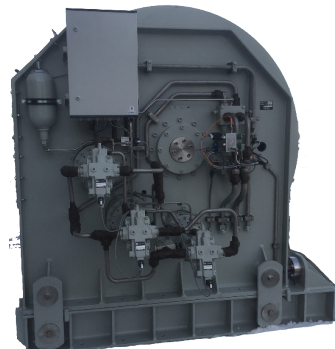

Control system design:

- Tension Control
- Tension Limiting
- Operation Logging

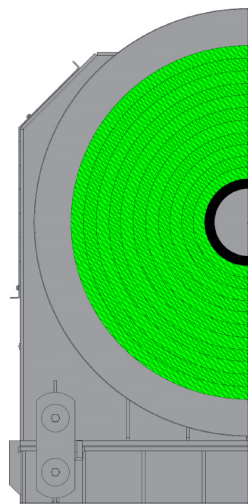

Layers	Pull	Capacity
1. Layer	20t	73m
30%	20t	165m
40%	20t	399m
50%	20t	704m
60%	20t	883m
70%	20t	1522m
80%	16t	2036m

Pull force and drum capacity for each layer based on a Ø64mm rope, 3.2m drum length and only usage of 80% of the drum.

PETTER'S MARINE HYDRAULICS aims to satisfy our customers by providing reliable products with an excellent performance and 24/7 customer support

For the customer that demands a little bit more, **PETTER'S MARINE HYDRAULICS** offers support contracts that ensures 24/7 technical phone support and on-site support within 24 hours if a breakdown or malfunction should occur. We do also offer proactive service contracts for periodic maintenance of all equipment, including software updates

TYPE TABLE

Type	Weight	Drum capacity on full drum, Rope: Ø64mm	Split drum (S)	Drum capacity on full drum, Ø64mm	
			Weight (S)	Drum 1	Drum 2
DW60-D20-L32-(S)	~7.9t	2350m	~8.9t	1860m	441m
DW60-D20-L25-(S)	~7.4t	1830m	~8.4t	1350m	441m
DW60-D20-L22-(S)	~7.1t	1617m	~8.1t	1130m	441m

DW60-D20-Lxx is only designed for use with fibre rope.



STANDARD MANEUVERING SOLUTIONS

PETTER'S MARINE HYDRAULICS

web: www.pmh.no

switchboard +47 73 96 26

E-mail: post@pmh.no