

THRUSTERS

PMH STR 80 - 250 - xH

A PETTER'S MARINE HYDRAULICS thruster is made for operating in demanding environments and tough conditions, providing EXCELLENT performance and high RELIABILITY in a COST EFFICIENT way. In the STR design, the motor is oriented orthogonally to the thruster tunnel, with a 90° transmission, making the thruster especially suited for mounting under the main propeller shaft.

The STR80-250 thruster is available with both electric and hydraulic drive, and is delivered with all necessary equipment, tailored to the customer's needs. Please see datasheet for STR80-250-xE. For hydraulic drive thrusters, we deliver pumps, valves, cooling system and an electronic control system.

The control systems are prepared for integration with thruster control systems such as PETTER'S MARINE HYDRAULICS' MOMOTOR PITCH THRUSTER CONTROL (MPTC) and dynamic positioning systems such as the KEEP POSITION (KP) system.

Please see the MPTC and KP brochures or visit PETTER'S MARINE HYDRAULICS' home page [WWW.PMH.NO](http://www.pmh.no) for more information on these products.

ORDER INFORMATION

The thrusters are available in aluminum (alloy 5083), steel and fiberglass, and with both hydraulic and electric drive. The overall length of the tunnel is adjusted to the individual hull on request. Upon order, please state material thickness of hull, as the material thickness of the thruster tunnel has to be dimensioned accordingly.



TECHNICAL SPECIFICATIONS

Hydraulic interface:	
A.B:	SAE 6000 PSI 1 1/2"
Drain:	M33x2
Propeller:	3 blades, fixed pitch
Max oil flow:	442 l/min
Max oil pressure:	260 bar
Max power:	250 hp / 184 kW
Max RPM:	830 (propeller)
Thrust:	> 2000 kg

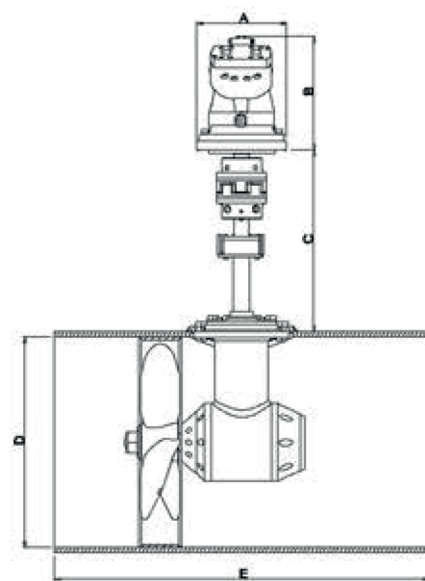

Part name:

Example: STR 80-250-AH

- Device type
Ø80 cm, 250 hp
- Drive
Hydraulic (H), Electric (E)
- Material
Aluminum (A), Steel (S),
Glass fiber (G)

A	B	C	D	E
360 mm	370 mm	700-1600 mm	840 mm	1500 mm