

THRUSTERS

PMH ST 45 - 50 - x

A PETTER'S MARINE HYDRAULICS thruster is made for operating in demanding environments and tough conditions, providing EXCELLENT performance and high RELIABILITY in a COST EFFICIENT way. Our thrusters have a simple, yet robust design, are highly adaptable and can be fitted to near any hull, especially catamarans. The ST design has a direct drive shaft between the propeller and motor, bringing the level of complexity and moving parts down to a minimum



The **ST45-50** thruster is a 50HP thruster that provides a thrust force of >400 kg, easily recognized by its compact design, angled tunnel and straight drive shaft. The great advantage of this thruster design is its low complexity, with few parts and low maintenance requirements. The fact that the thruster is angled in a downward manner proves to be its biggest advantage. Installing ST thrusters in catamaran or trimaran hulls assures that the water jet is pushed underneath the neighboring hull and not straight into it, which would dramatically reduce its efficiency. The thruster design is very compact and can be fitted in the narrowest of hulls. The ST design is available with hydraulic motors and in steel, aluminum and fiberglass tunnels.

ORDER INFORMATION

The thrusters are available in aluminum (alloy 5083), steel and fiberglass. The overall length of the tunnel is adjusted to the individual hull on request. Upon order, please state material thickness of hull, as the material thickness of the thruster tunnel has to be dimensioned accordingly

TECHNICAL SPECIFICATIONS

Hydraulic interface:	
A.B:	SAE 6000 PSI 3/4"
Drain:	7/8-14" UNF
Propeller:	3 blades, fixed pitch
Max oil flow:	82 l/min
Max oil pressure:	280 bar
Max power:	50 hp / 37kw
Max RPM:	1330
Thrust force:	> 400 kg
Sleeve lubricant:	Grease

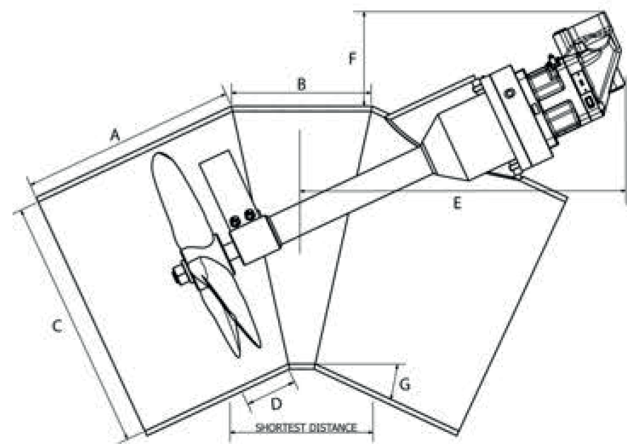

Part name:

Example: **ST 35-30-A**
 Device type: Ø35 cm, 30 hp
 Material: Aluminum (A), Steel (S), Glass fiber (G)

Datasheet ST 45-50-x July 2012

A	B	C	D	E	F	G
400* mm	290 mm	455 mm	135 mm	560 mm	240 mm	30°

*Some of the listed dimensions are flexible. By changing the parameter A on the left side (right side accordingly) the thruster is adaptable to most hull designs. Material thickness of the thruster tunnel is equal or greater the material thickness of the hull